

TRIPLE REPAIR CLAMPS FOR CAST IRON AND STEEL PIPES

Application:

Hydrex triple repair clamps are reliable solution for quick and cost effective repairs on different types of pipes (corrosion holes, impact damages, longitudinal cracks). They can be used for potable water and sewage installations.

Materials:

- body elements – ductile iron EN-GJS-500-7 (according to PN-EN 1563: 2012)
- gasket - EPDM or NBR rubber of equal thickness and grooved cover on all surface
- pushing-up plate - stainless steel 0H18N9 (according to PN-EN 10088-1: 2014-12 – 1.4301)
- studs, nuts, washers - galvanized steel (8.8) or stainless steel (A2/A4)

Self retaining bolts for easy installation with one wrench. Triple repair clamps are labelled with producers logo and nominal diameter and nominal pressure. All body elements are protected with epoxy powder coating (min. 250 µ). Working pressure PN 16.



TRIPLE REPAIR CLAMPS FOR CAST IRON AND STEEL PIPES

DN (mm)	height H (mm)	bolts	
		No.	M
80	152	6	16
100	153	6	16
125	179	6	16
150	242	9	16
200	271	9	16
250	342	9	16
300	342	9	16

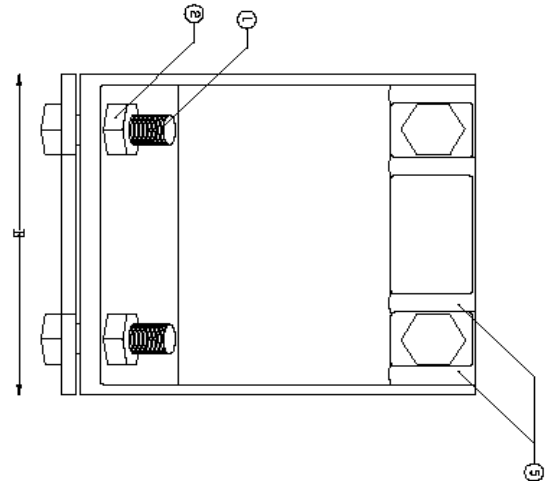
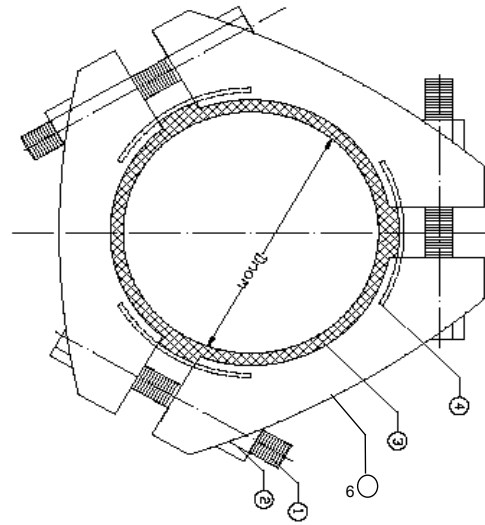

Component list:

1. Stud
2. Nut and washer
3. Gasket
4. Pushing-up plate
5. Stud socket
6. Body element